

This translation is provisional translation for reference, formally refer to the original text.

**ORDINANCE
FOR
TECHNICAL SPECIFICATIONS PERTAINING
TO POWER FIRE PUMPS**

**(Ordinance of the Ministry of Home Affairs No. 24
of October 15, 1986)**

**LATEST UPDATE: Ordinance of the Ministry of Internal Affairs
and Communications No. 23 of March 27, 2013**

In accordance with the provision of Article 21-16-3 paragraph (1) of the Fire Service Act (Act No. 186 of 1948), the ordinance to wholly revise the Ordinance for Technical Specifications Pertaining to Power Fire Pumps (Ordinance of the Ministry of Home Affairs No. 35 of 1974) shall be specified as follows.

CONTENTS

CHAPTER 1 GENERAL PROVISIONS (Article 1 ~ 7)..... 3

CHAPTER 2 AUTOMOTIVE FIRE APPLIANCES (Article 8 ~ 11)..... 6

CHAPTER 3 PORTABLE FIRE PUMPS (Article 12 ~ 15)..... 9

CHAPTER 4 AUTOMOTIVE FIRE APPLIANCES FOR LARGE VOLUME
FOAM TURRET (Article 16 ~ 18) 10

CHAPTER 5 PORTABLE FIRE PUMPS FOR LARGE VOLUME FOAM TURRET
(Article 19 and 20)..... 11

CHAPTER 6 TESTS PERTAINING TO POWER FIRE PUMPS (Article 21 ~ 30)..... 11

CHAPTER 7 TESTS PERTAINING TO POWER FIRE PUMPS FOR LARGE VOLUME
FOAM TURRETS (Article 31 ~ 36) 15

CHAPTER 8 MISCELLANEOUS PROVISIONS (Article 37)..... 17

SUPPLEMENTARY PROVISIONS 18

Ordinance for Technical Specifications Pertaining to Power Fire Pumps (Article 1~3)

CHAPTER 1 GENERAL PROVISIONS

(Purport)

Article 1 This Ordinance covers the technical specifications applicable to power fire pumps.

(Definitions)

Article 2 In this Ordinance, the meanings of the terms listed in the following items shall be as prescribed respectively in these items.

- (i) Power fire pump: A pumping system composed of a pump, internal combustion engine to drive the pump or an engine of which the performance is equivalent to or higher than this (hereinafter referred to as "the engine") and other necessary machinery and appliances.
- (ii) Automotive fire appliance: A power fire pump which is fixed to the chassis of a vehicle [meaning a vehicle prescribed in Article 2 paragraph (2) of the Road Transport Vehicle Act (Act No. 185 of 1951); the same shall apply hereinafter]
- (iii) Portable fire pump: A power fire pump which is transported manually without using a vehicle or which is transported with the pump mounted in a detachable manner to a vehicle to be towed manually or mounted to the chassis of a vehicle
- (iv) Automotive fire appliance for large volume foam turret: An automotive fire appliance used solely as disaster prevention equipment for a large volume foam turret prescribed in Article 13 paragraph (3) of the Cabinet Order for Enforcement of the Act on the Prevention of Disasters at Petroleum Industrial Complexes and Other Petroleum Facilities (Cabinet Order No. 129 on 1976)
- (v) Portable fire pump for large volume foam turret: A portable fire pump used solely as disaster prevention equipment for large volume foam turret prescribed in Article 13 paragraph (3) of the Cabinet Order for Enforcement of the Act on the Prevention of Disasters in Petroleum Industrial Complexes and Other Petroleum Facilities.
- (vi) Pump class: A class corresponding to the specified water discharge performance and high pressure water discharge performance of a pump prescribed in Article 21 paragraph (1).

(General Structure and Functions)

Article 3 The general structure and functions of a power fire pump shall conform to each of the following items.

- (i) During its use or travelling or transportation, it shall not generate any structural or functional abnormalities due to vibration, etc.
- (ii) Portions which may be touched by an operator among the rotating portions and portions which become hot shall be provided with suitable measures, including the installation of a cover, to prevent harm.
- (iii) Any portion which may be touched by an operator or inspector shall be provided with a necessary measure to prevent harm as well as to maintain strength, excluding the case where a sharp angle is required for proper functionality.
- (iv) In the case of a power fire pump capable of performing automatic pumping operation, adjustment of the water pressure, etc., such functions shall run without fail and the pump shall have a back-up operating device.
- (v) Electrical wiring, electrical terminals, electrical switches and other electrical components shall be protected by suitable measures so that they shall not suffer from any functional abnormalities due to moisture or water.
- (vi) A power fire pump shall not be accompanied by any auxiliary device which may have a harmful impact on its functions.

Ordinance for Technical Specifications Pertaining to Power Fire Pumps (Article 3~4)

- (vii) Metal couplings to be used for the suction port and discharge port of the pump shall conform to the provisions of the Ordinance for Technical Specifications Pertaining to Snap or Screw Type Metal Couplings Used for Fire Hoses and Screw Type Metal Couplings Used for Fire Suction Hoses (Ordinance of the Ministry of Internal Affairs and Communications No. 23 or 2013).
- (viii) The suction port of a pump [excluding Class D-1 and Class D-2 pumps, automotive fire appliances for a large volume foam turret and portable fire pump for large volume foam turret (hereinafter referred to as “power fire pumps for large volume foam turret”)] shall have a structure which allows the mounting of a strainer.
- (ix) The dry mass (meaning the total mass after the removal of all fuel, lubricant oil, cooling water and other liquids) of a portable fire pump (excluding a portable fire pump for a large volume foam turret) shall be as listed in the following table according to the grade of the pump.

Pump Class	Dry Mass (kilogrammes)
A-1	≦ 150
A-2	
B-1	
B-2	
B-3	≦ 100
C-1	
C-2	
D-1	≦ 25
D-2	≦ 15

- (x) The pressure gauge for a pump shall meet the requirements listed in the following.
 - (a) The pressure gauge for a pump shall have an accuracy equivalent to or higher than Class 1.6 of JIS [meaning the Japan Industrial Standards set forth in the Industrial Standardization Act (Act No. 185 of 1949); the same shall apply hereinafter] B7505-1 (Aneroid pressure gauges - - Part 1: Bourdon tube pressure gauges).
 - (b) The pressure gauge for a pump shall offer readings which can be read at night.
 - (c) The pressure gauge for a pump shall offer a pressure value which is indicated in a stable manner and which can be clearly read. In the case of an analogue type pressure gauge, the range of deflection of the pointer during continual water discharge operation shall be within five 5% [10% in the case of a portable fire pump] of the upper limit of the pressure range of the pressure gauge in question.
 - (d) A pressure gauge which is capable of measuring a pressure equivalent to or higher than the maximum pressure during normal state of use (including the situation where the discharge port is closed; the same shall apply hereinafter) shall be installed on the water discharge side of a pump.
 - (e) A pressure gauge capable of measuring a pressure which exceeds the range of between -0.1 MPa and 1.5 MPa (0.5 MPa in the case of a portable fire pump) shall be installed on the water suction side of a pump (excluding Class D-1 and Class D-2 pumps)

(Materials)

Article 4 The materials used for those power fire pump components listed in the left-hand column of the following table shall possess a strength and durability (tensile strength, bearing force and elongation) equivalent to or higher than those listed in the right-hand column of the said table.

Ordinance for Technical Specifications Pertaining to Power Fire Pumps (Article 4~7)

Component	Material
Impeller and guide	JIS H5120 (copper and copper alloy castings)
Impeller blade	JIS H5121 (copper alloy continuous castings)
	JIS H5202 (aluminium alloy castings)
Casing	JIS G5501 (grey iron castings)
	JIS G5502 (spheroidal graphite iron castings)
	JIS H51020 (copper and copper alloy castings)
	JIS H5121 (copper alloy continuous castings)
	JIS H5202 (aluminium alloy castings)
Pump shaft	JIS G4051 (carbon steel for machine structural use)
	JIS G4052 [structural steel with specified hardenability bands (H steel)]
	JIS G4053 (low alloy steel for machine structural use: nickel-chrome steel material and chrome-molybdenum steel material)
	JIS G4303 (stainless steel bars)
Inducer	JIS G5121 (corrosion-resistant cast steel for general applications)
	JIS H5120 (copper and copper alloy castings)
	JIS H5121 (copper alloy continuous castings)
	JIS H5202 (aluminium alloy castings)
Suction piping and discharge piping	JIS G3452 (carbon steel pipes for ordinary piping)
	JIS G3454 (carbon steel tubes for pressure service)
	JIS G3459 (stainless steel pipes)
	JIS G5501 (grey iron castings)
	JIS H4080 (aluminium and aluminium alloy extruded tubes and cold-drawn tubes)
	JIS H5202 (aluminium alloy castings)

Article 5 Deleted

(Suction Port)

Article 6 The inside diameter of the suction port of a pump shall be the one listed in the following table in correspondence with the pump classes; provided, however, that this shall not apply to those pumps of which the water discharge rate is 3.0 m³/ minute at a water discharge pressure of 0.85 MPa under the conditions of the standard water discharge test prescribed in Article 21 among Class A-1 pumps.

Pump Class	Inside Diameter (mm)
A-1	≦ 125
A-2	≦ 100
B-1	≦ 100
B-2	≦ 90
B-3	≦ 75
C-1	≦ 65
C-2	≦ 65
D-1	≦ 40
D-2	≦ 40

(Indications)

Article 7 The information specified in the following items shall be indicated on all power fire pumps in an easily observable place in such a manner that the subject information may not be readily erased.

- (i) Name of manufacturer
- (ii) Year of manufacture and manufacturing number
- (iii) Classification of either automotive fire appliance or portable fire pump
- (iv) Pump class

Ordinance for Technical Specifications Pertaining to Power Fire Pumps (Article 7~8)

- (v) Notification number
- (vi) Mixing ratio in the case of a pump using mixed gasoline
- (vii) Following items in the case of a power fire pump for large volume foam turret
 - (a) Indication of purpose of use for a large volume foam turret
 - (b) Large volume water discharge pressure and water discharge rate
 - (c) Lower limit for working pressure [meaning the working pressure prescribed in Article 2 item (ix) of the Ordinance for Technical Specifications Pertaining to Fire Hoses (Ordinance of the Ministry of Home Affairs No. 27 of 1968)] of a connectable fire hose
- (2) In addition to what is prescribed in the preceding paragraph, the name and nature of operation shall be indicated at the operating portion of a power fire pump while, in the case of a portion subject to special handling, a warning to that effect shall be indicated in such a manner that the subject information may not be readily erased; provided, however, that this shall not apply to an operating portion where the absence of the said indication does not hinder the use of the operating portion.

CHAPTER 2 AUTOMOTIVE FIRE APPLIANCES

(Pump of Automotive Fire Appliance)

Article 8 The pump of an automotive fire appliance (excluding automotive fire appliances for large volume foam turret; the same shall apply in the rest of this chapter) shall conform to each of the following items.

- (i) The pump shall have a structure which enables its disassembly and detachment; provided, however, that this shall not apply to a pump with a special structure or component where no replacement, greasing or maintenance is required.
- (ii) The pump and all piping shall have a structure which enables effective drainage within 5 minutes.
- (iii) The drain cock of the pump shall be operable in concert with the lever to drive the pump; provided, however, that this shall not apply to a drain cock where its special structure does not require such concerted operation.
- (iv) The drive unit of the pump shall meet those requirements listed in the following.
 - (a) The drive unit shall be effectively lubricated by means of forcible lubrication or splash lubrication, etc.
 - (b) The drive unit shall have an inspection opening to check the oil level or a device to help inspection.
 - (c) The drive unit shall have an oil filler port, discharge port and bleeder; provided, however, that these ports may be used for dual purposes.
- (v) The transmission shaft of the pump's drive unit shall have a measure designed to effectively buffer the axial load.
- (vi) The priming device shall meet those requirements listed in the following.
 - (a) A priming device using a vacuum pump shall meet the following requirements.
 1. The closure of the water pass and the stoppage of transmission of power to the vacuum pump shall be automatically done after the completion of pumping but before the pump pressure reaches 0.3 MPa.
 2. A vacuum pump using a lubricant shall automatically conduct the start and stop of the resupply of the lubricant during the operation of the said vacuum pump.
 3. The vacuum pump shall not start up with the vibration of the engine.
 4. The lubricant tank for a vacuum pump shall hold the necessary amount of lubricant to conduct three or more pumping operations in the case where a 10 meters (6 meters in the case of a portable fire pump) long suction hose (hereinafter referred

Ordinance for Technical Specifications Pertaining to Power Fire Pumps (Article 8~9)

to as “a standard suction hose”) is connected to a suction port of the pump and the suction lift is 3 meters (hereinafter referred to as “the standard suction test conditions”), shall not allow the outflow of lubricant unless the vacuum pump is in operation, shall allow checking of the amount of lubricant and shall not allow the inflow of water from the vacuum pump.

5. In the case of lubricant used with a vacuum pump being liable to freezing, a measure to prevent functional degradation shall be in place.
- (b) A priming device using the breathing function of the engine shall be capable of both avoiding functional degradation due to overheating or freezing and not interrupting the operation of the engine.
- (c) A self-priming type priming device shall not be liable to damage, etc. due to freezing of the priming water.
- (vii) In the case of a pump where there are two or more suction ports and its water discharge performance is satisfied by means of using two or more of the suction ports in question, it shall have a priming device which has a structure to use water flow in the suction hose on one side to pump water to the suction hose on the other side (hereinafter referred to as “an ejector”) and shall be capable of verifying the completion of pumping operation.

(Engine of Automotive Fire Appliance)

Article 9 The engine to drive the pump of an automotive fire appliance shall conform to each of the following items.

- (i) The cooling system shall meet those requirements listed in the following.
 - (a) A water-cooled cooling system shall meet the following requirements.
 1. It shall have a structure to prevent wetting of the carburettor and electrical devices due to leakage of the cooling water.
 2. It shall have an instrument which indicates the temperature of the cooling water in a position which is easily visible.
 3. In the case of a cooling system equipped with an auxiliary cooler, the said auxiliary cooler shall meet the following requirements.
 - i. It shall be corrosion resistant against water, anti-freezing fluid, etc., shall not suffer functional degradation due to water pressure or vibration and shall not require more than 5 minutes to drain the cooling water.
 - ii. The cooling water discharge port shall be positioned between the shut-off valve for the automatic discharge port and the discharge port of the pump and above the lowest section of the piping on the discharge side.
 - iii. It shall be able to regulate the volume of cooling water.
 - iv. It shall be equipped with a cooling water filtration device which can be easily cleaned without stopping water conveyance to the engine.
 - (b) An air-cooled cooling system equipped with an air-cooled ventilator shall have a structure to prevent any incursion of foreign matters which may impede the function of the said air-cooled ventilator.
- (ii) The lubricating system shall meet the following requirements.
 - (a) In the case of a system where lubricant is circulated by an oil pump, it shall be equipped with a pressure indication device and a safety valve; provided, however, that this shall not apply to two-stroke gasoline engines.
 - (b) It shall have an indicator which indicates the temperature of the lubricant in a position which is easily visible.
- (iii) The fuel system shall meet the following requirements.
 - (a) It shall have a fuel gauge which is capable of indicating 25% or more but 75% or less of

Ordinance for Technical Specifications Pertaining to Power Fire Pumps (Article 9~11)

- the fuel tank capacity; provided, however, that this shall not apply to fuel systems where the amount of fuel can be easily verified from outside the fuel tank.
- (b) It shall have a fuel filtration device.
 - (c) The fuel tank shall have a strength equivalent to a steel tank or higher and shall be corrosion-resistant against fuel.
 - (d) The capacity of the fuel tank shall be sufficient to hold an amount of fuel which is capable of conducting continual water discharge operation for 1 hour or more with the specified water discharge performance prescribed in Article 21.
 - (e) The fuel tank shall have a fuel discharge port as well as a measure designed to prevent a significant change of the pressure inside the tank.
 - (f) In the case where the fuel tank is installed above the exhaust pipe, the fuel tank shall have a measure to prevent any adverse impact of the heat released from the exhaust pipe.
 - (g) The fuel filling port shall be installed so that any spilled fuel during refuelling operation shall not be subject to any adverse impact of the heat released from the exhaust pipe.
 - (h) Joints of the fuel piping made of rubber, synthetic resin, etc. shall have a measure designed to prevent separation.
- (iv) The air cleaner shall have a measure to prevent its functional degradation by rainwater or spilled water.
 - (v) The exhaust device shall have a measure to prevent any adverse impact on other devices.
 - (vi) The capacity of the battery shall be 80 Ah or more as the 5 hour rate.
 - (vii) The ignition device shall have a measure to prevent its functional degradation due to the incursion of water or oil or high temperatures.
 - (viii) A device to limit the rotating speed of the engine (hereinafter referred to as “the governor”) shall be installed.
 - (ix) A device to adjust the rotating speed of the engine (hereinafter referred to as “the throttle”) shall be installed in a position where the throttle can be operated while the pressure gauge of the pump is monitored.
 - (x) A muffling device shall be installed so that fire-fighting activities shall not be impeded by engine noise.

(Colour Coding of Pipes)

Article 10 An automotive fire appliance shall employ a colour coding system where the colours listed in the right-hand column of the following table are applied to the entire outer surface or part thereof of pipes for easy recognition in accordance with the types of substances flowing through these pipes; provided, however, that this shall not apply to pipes used for engine, pipes of which the inside diameter is 25 millimeters or more and pipes of which the contents can be seen from outside.

Substance Flowing through Pipe	Colour
Water	Pale blue
Air	White
Lubricant	Yellow
Grease	Brown
Fuel	Red

(Equipment of Automotive Fire Appliance)

Article 11 The equipment of an automotive fire appliance shall conform to each of the following items.

- (i) A motor vehicle shall have steps and other equipment for safe and easy embarkation and disembarkation.

Ordinance for Technical Specifications Pertaining to Power Fire Pumps (Article 11~14)

- (ii) The operating section, engine section and pump section shall have lighting which is capable of effectively illuminating the said sections while the upper section of an automotive fire appliance shall have a search light.
- (iii) Either the front section or rear section of the chassis shall have a hook.
- (iv) In addition to those listed in the three preceding items, the appliances or tools listed in the following shall be provided as required.
 - (a) Playpipe
 - (b) Nozzle
 - (c) Suction hose
 - (d) Screen for the suction hose
 - (e) Strainer for the suction hose
 - (f) Strainer for the suction port
 - (g) Adaptor for the hydrant
 - (h) Fire hose
 - (i) Necessary tools

CHAPTER 3 PORTABLE FIRE PUMPS

(Pump of Portable Fire Pump)

Article 12 The pump of a portable fire pump (excluding portable fire pumps for a large volume foam turret; the same shall apply in the rest of this chapter) shall conform to each item of Article 8 [excluding items (iii) to (v), item (iv)-(a)-1. and 3. and item (vii)].

(Engine of Portable Fire Pump)

Article 13 The engine of a portable fire pump shall conform to each of the following items in addition to conform to each item of Article 9 paragraph (1) [excluding item (i)-(a)-2. and 3, item (ii)-(b), item (iii)-(c) and (d) and item (vi)].

- (i) The water-cooled cooling device shall be corrosion resistant against water and anti-freezing fluid, etc., shall not suffer functional degradation due to water pressure or vibration and shall not require more than 5 minutes to drain the cooling water.
- (ii) The fuel tank shall meet the following requirements.
 - (a) It shall have a strength equivalent to a steel tank or higher; provided, however, that this shall not apply to a fuel tank of Class D-1 and Class D-2 pumps.
 - (b) It shall be corrosion resistant against fuel.
 - (c) It shall be able to hold an amount of fuel capable of conducting continual water discharge operation for 30 minutes or more with the specified water discharge performance prescribed in Article 21.
- (iii) In the case of a portable fire pump equipped with a battery, the capacity of the said battery shall be 15 Ah or more as the 5 hour rate (12 Ah as the 10 hour rate for a battery of Class C-1, Class C-2, Class D-1 and Class D-2 pumps).

(Transporting Apparatus for Portable Fire Pump)

Article 14 The transporting apparatus for a portable fire pump shall conform to each of the following items.

- (i) The mount shall not suffer any deformation due to the weight of the pump, engine, etc.
- (ii) The chassis of a vehicle to be towed manually or a motor vehicle shall meet the following requirements.
 - (a) It shall not suffer from any localised deformation due to the weight of the pump, engine, etc.

Ordinance for Technical Specifications Pertaining to Power Fire Pumps (Article 14~17)

- (b) Such mechanical portions as the frame, spring, axle, etc. shall be able to support full load operation at the scene of a fire or another disaster.
- (c) In the case of the chassis of a two-wheel vehicle, it shall have a good load balance between the front and back of the axle and shall have a stand at both the front and rear ends of the chassis.

(Equipment of Portable Fire Pump)

Article 15 A portable fire pump shall have the appliances or tools listed in Article 11 item (iv) as required.

CHAPTER 4 AUTOMOTIVE FIRE APPLIANCES FOR LARGE VOLUME FOAM TURRET

(Pump of Automotive Fire Appliance for Large Volume Foam Turret)

Article 16 The pump of an automotive fire appliance for large volume foam turret shall conform to each of the following items in addition to conforming to each item of Article 8 [excluding item (vi)-(a)-1. and 4. and item (vii)].

- (i) It shall have a measure designed to prevent the operating pressure of the fire hose as indicated on the said automotive fire appliance for large volume foam turret being exceeded.
- (ii) A pump which uses a priming device utilizing a vacuum pump shall meet the following requirements.
 - (a) The closure of the water pass and the transmission of power to the vacuum pump shall be automatically done after the completion of pumping; provided, however, that this shall not apply to a vacuum pump which has an independent power supply.
 - (b) The lubricant tank for the vacuum pump shall hold the necessary amount of lubricant to conduct three or more pumping operations in the case where a 10 meters long suction hose (hereinafter referred to as "a standard large volume suction hose") is connected to each of all suction ports of the pump and the suction lift is 3 meters (hereinafter referred to as "the standard large volume suction test conditions"), shall not allow the outflow of lubricant unless the vacuum pump is operated, shall allow checking of the amount of lubricant and shall not allow the inflow of water from the vacuum pump.
- (iii) A pump which uses a pump submerged in water or afloat on the water surface to assist pumping operation by the pump (hereinafter referred to as "a submersible pump") shall meet the following requirements.
 - (a) The suction port of the submersible pump shall have a structure which enables the mounting of a strainer.
 - (b) The operating section of the submersible pump shall have a device which enables checking of the operating situation of the said submersible pump during the operation and a safety device for an emergency stop, etc.
- (iv) The suction port of the pump shall have a structure which enables the mounting of a strainer; provided, however, that this shall not apply to a pump which uses a submersible pump or fire suction hose mounted with a strainer.

(Engine of Automotive Fire Appliance for Large Volume Foam Turret)

Article 17 The engine to drive the pump of an automotive fire appliance for a large volume foam turret shall conform to each of the following items in addition to conforming to each item of Article 9 [excluding item (i)-(a)-3.-ii. and item (iii)-(d)].

- (i) In the case of a water-cooled cooling system equipped with an auxiliary cooler, the

Ordinance for Technical Specifications Pertaining to Power Fire Pumps (Article 17~21)

cooling water discharge port of the said auxiliary cooler shall be positioned above the lowest section of the piping on the discharge side.

- (ii) The capacity of the fuel tank shall be sufficient to hold an amount of fuel capable of conducting continual water discharge operation for 2 hours or more with the water discharge performance prescribed in Article 341.

(Application Mutatis Mutandis)

Article 18 The provisions of Article 10 and Article 11 item (i) to item (iii) shall apply *mutatis mutandis* to automotive fire appliances for large volume foam turret.

CHAPTER 5 PORTABLE FIRE PUMPS FOR LARGE VOLUME FOAM TURRET

(Equipment of Portable Fire Pump for Large Volume Foam Turret)

Article 19 The operating section, engine section and pump section of a portable fire pump for a large volume foam turret shall have lighting which is capable of effectively illuminating the said sections.

(Application Mutatis Mutandis)

Article 20 The provisions of Article 10, Article 14, Article 16 and Article 17 shall apply *mutatis mutandis* to portable fire pumps for large volume foam turret.

CHAPTER 6 TESTS PERTAINING TO POWER FIRE PUMPS

(Water Discharge Performance Test of Pump)

Article 21 The pump (excluding a pump of a power fire pump for large volume foam turret; the same shall apply in the rest of this chapter) shall satisfy the specified water discharge performance listed in the middle column of the Appended Table and the high pressure water discharge performance listed in the right-hand column of the said table in accordance with the its class listed in the left-hand column of the said table. Meanwhile, the specified water discharge performance and high pressure water discharge performance shall be as specified in each of the following items.

- (i) In the case where a standard suction hose is connected to the suction port of a pump of the specified water discharge performance with a suction lift of 3 meters (hereinafter referred to as “the standard water discharge test conditions”), when the static water discharge pressure obtained through the adjustment of the diameters of the nozzle, orifice, etc. (hereinafter referred to as “the static water discharge pressure”) is considered to be the specified water discharge pressure for the specified water discharge performance listed in the middle column of the Appended Table (hereinafter referred to as “the specified water discharge pressure”), the pump shall have the specified water discharge volume for the specified water discharge performance listed in the middle column of the Appended Table.
- (ii) In the case where the static water discharge pressure is considered to be the high water discharge pressure for the high pressure water discharge performance in the right-hand column of the Appended Table under the standard water discharge test conditions for the high pressure water discharge performance (hereinafter referred to as “the high water discharge pressure”), the pump shall have the high pressure water discharge rate for the high pressure water discharge performance listed in the right-hand column of the said table.

Ordinance for Technical Specifications Pertaining to Power Fire Pumps (Article 21~22)

- (2) The static water discharge pressure shall be measured in the state where the stream straightener (meaning that listed in the Appended Figure) is attached to the discharge port of the pump and the strainer is attached to both the suction port of the pump and the suction hose (in the case of Class D-1 and Class D-2 pumps, in the state where the strainer is attached to the suction hose).
- (3) The efficiency of the pump [meaning the value obtained by dividing the water power by the shaft power of the pump in the state set forth in paragraph (1); the same shall apply in the rest of this paragraph] shall be 65% or more for the pump of an automotive fire appliance and 55% or more for the pump of a portable fire pump (in the case of Class D-1 and Class D-2 pumps, 25% or more); provided, however, that this shall not apply to pumps with a special structure of which the pump efficiency is indicated in an easily visible place in such a manner that the subject information may not be easily erased.

(Continual Water Discharge Test)

Article 22 In the case where a power fire pump (excluding power fire pumps for large volume foam turret; the same shall apply in the rest of this chapter) continually conducts water discharge operation for 6 hours with the maximum load at the specified water discharge pressure followed by continual water discharge operation for 2 hours either with the maximum load at the high water discharge pressure or with the maximum engine output [or in the case where continual water discharge operation is conducted for eight 8 hours with the maximum load at the specified water discharge pressure for Class D-1 or Class D-2 pumps] (hereinafter referred to as "continual water discharge operation"), the said pump shall conform to each of the following items.

- (i) During continual water discharge operation, the water discharge pressure shall not fall below the specified water discharge pressure or high water discharge pressure.
 - (ii) During continual water discharge operation, the temperature of such components as the pump shaft, bearings, etc. and the noise generated by the said components shall be stable and the said components shall not conspicuously vibrate.
 - (iii) The wear and tear, damage, etc. of the components shall not reach a level which impedes water discharge operation.
- (2) The temperature of the portion listed in each of the following items during continual water discharge operation shall not exceed the temperature specified in each item in question.
 - (i) Cooling water of the water-cooled engine: 110°C for the pressure type and 95°C for other types
 - (ii) Surface of the ignition plug seat of the air-cooled engine: 305°C
 - (iii) Surface of the cylinder case of the air-cooled engine: 205°C
 - (iv) Lubricant of the engine [excluding the lubricant in item (vi)]: 130°C for the pressure type and 95°C for other types
 - (v) Lubricant of the drive unit of the pump (excluding the lubricant in the following item): 115°C
 - (vi) Lubricant supplying lubricant to the pressure type engine and drive unit of the pump: 130°C
 - (3) The maximum difference in the compression pressure of each cylinder of the engine shall be within 20% of the mean value of the said cylinder compression pressures in the case where the engine is run as specified in each of the following items in correspondence with the type of power fire pump listed in each said item (in the case where the engine is run with the maximum position of the throttle for an engine using gasoline as the fuel) immediately after continual water discharge operation.
 - (i) Automotive fire appliance: When the engine is run at the rated speed and at the rated voltage of the starter motor in the state where the temperature of the lubricant of the

Ordinance for Technical Specifications Pertaining to Power Fire Pumps (Article 22~25)

- engine is 60°C or higher but 80°C or lower
- (ii) Portable fire pump: When the engine is run with start-up operation
- (4) Continual water discharge operation shall be conducted in the state where such necessary lighting apparatus as gauge lamps and illuminating lamps are lit.

(Pressure Test)

Article 23 The pump and its piping shall not generate such abnormalities as water leakage and conspicuous deformation when the pressure specified in each of the following items is applied for 3 minutes in correspondence with the class listed in each of the said items.

- (i) Pump and piping on the discharge side: Pressure which is 1.5 times the maximum value of the pump pressure generated when the pump is operated in the normal state of use
- (ii) Piping on the suction side: Pressure of 1.5 MPa for automotive fire appliances or 1.0 MPa for portable fire pumps (0.5 MPa for Class D-1 and Class D-2 pumps)

(Corrosion Test)

Article 24 The materials used for the pump, suction piping, discharge piping and those portions which may be in contact with the cooling water and water for discharge shall be erosion resistant; provided, however, that this shall not apply to those which do not malfunction due to corrosion when they have undergone a cycle of exposure to salt spray for 8 hours and standing still for 16 hours as specified by JIS Z2371 (Methods of salt spray testing) 5 times followed by water cleaning and standing still for 24 hours for natural drying.

(Functional Test of Vacuum Pump)

Article 25 A vacuum pump shall conform to each of the following items.

- (i) In the state where a standard suction hose of which the diameter is the same as that of the suction port of the pump to which the said suction hose is attached and the outer end of the suction hose is blocked, the air pressure at the said outer end shall reach 84% (42% in the case of Class D-1 and Class D-2 pumps) of the atmospheric pressure at the start of the pumping operation of the vacuum pump within 30 seconds from the start of the pumping operation at the rated speed and the vacuum leakage during a period of 30 seconds after the stoppage of the vacuum pump shall be 1.3 KPa or less.
- (ii) The vacuum pump and drive unit of the said vacuum pump shall not suffer from either any structural or functional abnormality when pumping operation of the said vacuum pump at the rated speed is conducted 1,000 times under the standard suction test conditions.
- (iii) In the case of a vacuum pump of the type where lubricant is circulated, it shall not suffer from either any structural or functional abnormality under any of the following conditions when a standard suction hose is attached to one suction port of the pump and the said vacuum pump is run at the rated speed for pumping operation.
 - (a) State where the suction lift is 1 meter
 - (b) State of the standard suction test conditions
 - (c) State where the centre of the suction hose is positioned 30 centimeters above the suction port of the pump in the state of both (a) and (b) above
 - (d) Both states where the water inside the pump is not completely drained and completely drained in each of the states of (a) through (c) above
- (iv) In the state where a standard suction hose of which the diameter is the same as that of the suction port of the pump to which the said suction hose is attached and the outer end of the said suction hose is blocked, the vacuum pump shall not suffer from either any structural or functional abnormality when it is continually run for 5 minutes after the air pressure in the suction hose has reached 84% (42% in the case of Class D-1 and

Ordinance for Technical Specifications Pertaining to Power Fire Pumps (Article 25~29)

Class D-2 pumps) of the atmospheric pressure at the start of the running of the vacuum pump at the rated speed.

(Functional Test of Ejector)

Article 26 When pumping operation is conducted with a nozzle diameter of 26 millimeters (29 millimeters when the nominal diameter class of the suction hose is 90 or more) and a pump pressure of 0.5 MPa under the standard water discharge test conditions, the ejector shall be able to maintain a pump pressure of 0.25 MPa or higher and shall complete pumping operation within 60 seconds (90 seconds when the nominal diameter class of the suction hose is 100 or more).

(Continual Operation Test of Engine)

Article 27 The engine (limited to those of which the performance cannot be verified by the continual water discharge test specified in Article 22; the same shall apply in the rest of this paragraph and the following paragraph) shall conform to each of the following items when it is continually run for 8 hours in the state of full load (for an engine of which the structure does not allow the state of full load, the state where the opening angle of the gas valve or the position of the throttle of the carburettor is at the maximum permissible limit).

- (i) When the performance of the engine is measured using the net horsepower test method in JIS D1001 (Road vehicles ... Engine power test code) during engine operation, the output and speed of the said engine shall not decay.
 - (ii) The vibration of the engine and noise generated by components of the engine shall be stable during engine operation and the temperature of each portion of the said engine shall not exceed the temperature specified in Article 22 paragraph (2) [excluding item (v) of the said paragraph].
 - (iii) There shall not be any wear, damage or carbon deposit to any of the components which may impede the operation of the engine and there shall be no necessity for the replacement of components (excluding the spark plugs) after the said operation.
- (2) In the case referred to in the preceding paragraph, the rate of circulating water flow when the engine is accompanied by an auxiliary cooler shall not exceed the value calculated by the following equation.

$$Q = P_o \times 0.55$$

Where,

Q: Rate of circulating water flow (unit: liters per minute)

P_o: Rated output of the engine (unit: kilowatts)

(Low Temperature Starting Test)

Article 28 The engine shall start within for 45 seconds of the time of the commencement of starting operation in the state where the temperature of the said engine is -20°C.

- (2) In the case referred to in the previous paragraph, the equipment of an automotive fire appliance shall be based on attachment equipping condition B of JIS D1001 (Road vehicles ... Engine power test code) while the speed of the said engine shall be 85% of the speed when the engine is run by a starter motor as specified in JIS D1021 (Automobiles ... Starting test method).

(Performance Test of Governor of Engine)

Article 29 The governor of the engine shall conform to each of the following items in the case where the engine is instantaneously put in the state of no load during its operation with a fully opened throttle while the pump is in the state prescribed in Article 21 paragraph (1)

Ordinance for Technical Specifications Pertaining to Power Fire Pumps (Article 29~32)

item (ii) [state prescribed in paragraph (1) item (i) of the said article for Class D-1 and Class D-2 pumps].

- (i) In the case where the speed of the engine suddenly increases, the said speed at the moment when the said speed starts to decrease with the operation of the governor shall be within 120% (130% for Class D-1 and Class D-2 pumps) of the rated speed of the said engine.
- (ii) The speed in the state where the said speed of the engine is stable with the operation of the governor (hereinafter referred to as “the statically determinate speed” in this item and the following item) shall be within 110% (120% for Class D-1 and Class D-2 pumps) of the rated speed of the said engine while the range of fluctuation of the statically determinate speed of the said engine shall be within 10% of the rated speed of the said engine.
- (iii) The time for the speed of the engine to reach the statically determinate speed from the moment when the engine is put in the state of no load shall be within 10 seconds.

(Water Loss Test)

Article 30 A power fire pump shall be capable of discharging water without pumping operation under the standard water discharge test conditions in the case where the engine is stopped during water discharge operation with the discharge port being open and then restarted after three (3) minutes.

CHAPTER 7 TESTS PERTAINING TO POWER FIRE PUMPS FOR LARGE VOLUME FOAM TURRETS

(Water Discharge Performance Test of Pump)

Article 31 The pump of a power fire pump for large volume foam turret in the state where a standard large volume suction hose is connected to its suction port with a suction lift of 3 meters or in the state where a submersible pump is connected using a fire hose with the difference in height between the pump and the said submersible pump being the design value shall have the design water discharge rate in the case where the static water discharge pressure obtained by adjustment of the diameters of the nozzle and orifice (hereinafter referred to as “the static large volume water discharge pressure”) is 0.7 MPa or more and is the design pressure (hereinafter referred to as “the large volume water discharge pressure”).

- (2) The static large volume water discharge pressure shall be measured in the state where a steam strainer (meaning that shown in the Appended Figure) and strainer are attached to the discharge port of the pump and either the suction port of the pump or suction hose (suction port of a submersible pump for a pump using a submersible pump) respectively.

(Continual Water Discharge Test)

Article 32 A power fire pump for large volume foam turret shall conform to each of the following items in the case where discharge operation is continually conducted for 8 hours with the maximum load at the large volume water discharge pressure (hereinafter referred to as “continual large volume water discharge operation”).

- (i) During continual large volume water discharge operation, the water discharge pressure shall not fall below the large volume water discharge pressure.
- (ii) During continual large volume water discharge operation, the temperature of such components as the pump shaft and bearings and the noise generated by the said components shall be stable and the said components shall not conspicuously vibrate.
- (iii) The wear and tear, damage, etc. of the components shall not reach a level which im-

Ordinance for Technical Specifications Pertaining to Power Fire Pumps (Article 32~34)

- pedes water discharge operation.
- (2) The temperature of the portion listed in each item of Article 22 paragraph (2) during continual large volume water discharge operation shall not exceed the temperature specified in each item in question.
 - (3) The maximum difference in the compression pressure of each cylinder of the engine of a power fire pump for large volume foam turret shall be within 20% of the mean value of the said cylinder compression pressures in the case where the engine is run with start-up operation (in the case where the engine is run with the maximum position of the throttle for an engine using gasoline as the fuel) immediately after continual large volume water discharge operation.
 - (4) Continual large volume water discharge operation shall be conducted in the state where such necessary lighting apparatus as gauge lamps and illuminating lamps are lit.

(Pressure Test)

Article 33 The pump and piping of a power fire pump for large volume foam turret shall not generate any abnormality, such as water leakage and conspicuous deformation, when the pressure specified in each of the following items is applied for 3 minutes in correspondence with the category listed in each of the said items.

- (i) Pump and piping on the discharge side: Pressure which is 1.5 times the maximum value of the pump pressure generated when the pump is operated in the normal state of use
- (ii) Piping on the suction side: Pressure of 1.5 MPa or a pressure which is 1.5 times the maximum value of the pressure on the suction side of the pump when the pump is operated in the normal state of use, whichever is greater

(Functional Test of Vacuum Pump)

Article 34 The vacuum pump of a power fire pump for large volume foam turret shall conform to each of the following items.

- (i) In the state where standard large volume suction hoses of which the diameter is the same as that of all of the pump's suction ports to which the said suction hoses are connected and the outer end of each of the said suction hoses is blocked, the air pressure at the said outer ends shall reach 84% of the atmospheric pressure at the start of the pumping operation within the design time from the start of the pumping operation and the vacuum leakage during a period of 30 seconds after the stoppage of the vacuum pump shall be 1.3 KPa or less.
- (ii) The vacuum pump and drive unit of the said vacuum pump shall not suffer from either any structural or functional abnormality when pumping operation of the said vacuum pump at the rated speed is conducted 1,000 times under the standard large volume suction test conditions.
- (iii) In the case of a vacuum pump of the type where lubricant is circulated, it shall not suffer from either any structural or functional abnormality under any of the following conditions when standard large volume suction hoses are attached to all of the suction ports of the pump and the said vacuum pump is run at the rate speed for pumping operation.
 - (a) State where the suction lift is 1 m.
 - (b) State of the standard large volume suction test conditions
 - (c) State where the centre of the suction hose is positioned 30 centimeters above the suction port of the pump in the state of both (a) and (b) above
 - (d) Both states where the water inside the pump is not completely drained and completely drained in each of the states of (a) through (c) above

Ordinance for Technical Specifications Pertaining to Power Fire Pumps (Article 34~37)

- (iv) In the state where standard large volume suction hoses of which the diameter is the same as that of all the suction ports are connected to all the suction ports of the pump and the outer end of each of the said suction hoses is blocked, the vacuum pump shall not suffer from either any structural or functional abnormality when it is continually run for 5 minutes after the air pressure in the suction hoses has reached 84% of the atmospheric pressure at the start of the running of the vacuum pump at the rated speed.

(Performance Test of Governor of Engine)

Article 35 The governor of the engine of a power fire pump for large volume foam turret shall conform to each item of Article 29 in the case where the said engine is instantaneously put in the state of no load during its operation with a fully opened throttle while the pump is in the state prescribed in Article 31.

(Application Mutatis Mutandis)

Article 36 The provisions of Article 24, Article 27 and Article 28 shall apply *mutatis mutandis* to power fire pumps for large volume foam turrets. In this case, the term "Article 22" in Article 27 paragraph (1) shall be deemed to be replaced by "Article 32".

CHAPTER 8 MISCELLANEOUS PROVISIONS

(Special Provision for Standards)

Article 37 In the case where the Minister of Internal Affairs and Communications finds that a power fire pump pertaining to new technological development has a performance equivalent to or higher than a power fire pump which conforms to the provisions of this Ordinance based on a reasonable judgement in terms of its shape, structure, materials and performance, the technical specifications specified by the Minister of Internal Affairs and Communications shall apply notwithstanding the provisions of this Ordinance of the Ministry.

Ordinance for Technical Specifications Pertaining to Power Fire Pumps (Supplementary Provisions)

SUPPLEMENTARY PROVISIONS

This Ordinance shall come into force as from January 1, 1986.

Supplementary Provisions (Ordinance of the Ministry of Home Affairs No. 43 of December 22, 1997)

- (1) This Ordinance shall come into force as from the day of promulgation.
- (2) Power fire pumps which were notified to the Minister of Home Affairs pursuant to the provisions of Article 21-16-4 paragraph (1) of the Fire Service Act prior to the day of enforcement of this Ordinance shall be deemed to be power fire pumps which conform to the specifications of the Ordinance for Technical Specifications Pertaining to Power Fire Pumps after the revision.

Supplementary Provisions (Ordinance of the Ministry of Home Affairs No. 37 of September 28, 1998) Excerpt

(Effective Date)

Article 1 This Ordinance shall come into force as from October 1, 1999.

(Transitional Measures)

Article 2 With regard to the tests pertaining to fire extinguishers, fire extinguishing agents, automatic closed sprinkler heads, fire hoses, deluge valves, foam concentrates, detectors and transmitters, water flow detection devices, snap type metal couplings and screw type metal couplings for which an application to have a machine or tool, etc. subject to inspection tested has already been made to the Japan Fire Equipment Inspection Institute at the time of enforcement of this Ordinance, the provisions then in force shall remain applicable.

- (2) The model approval pertaining to those fire extinguishers which have already received model approval and model approval pertaining to those fire extinguishers which have received model approval based on the results of tests governed by the provisions then in force pursuant to the provision of the preceding paragraph at the time of enforcement of this Ordinance shall be deemed to be model approval pursuant to the specifications prescribed in the Ordinance for Technical Specifications Pertaining to Fire Extinguishers after the revision pursuant to the provision of Article 1.
- (3) The model approval pertaining to those fire extinguishing agents which have already received model approval and model approval pertaining to those fire extinguishing agents which have received model approval based on the results of tests governed by the provisions then in force pursuant to the provision of paragraph (1) at the time of enforcement of this Ordinance shall be deemed to be model approval pursuant to the specifications prescribed in the Ordinance for Technical Specifications Pertaining to Fire Extinguishing Agents after the revision pursuant to the provision of Article 2.
- (4) The model approval pertaining to those automatic closed sprinkler heads which have already received model approval and model approval pertaining to those automatic closed sprinkler heads which have received model approval based on the results of tests governed by the provisions then in force pursuant to the provision of paragraph (1) at the time of enforcement of this Ordinance shall be deemed to be model approval pursuant to the specifications prescribed in the Ordinance for Technical Specifications Pertaining to Automatic Closed Sprinkler Heads after the revision pursuant to the provision of Article 3.
- (5) The model approval pertaining to those fire hoses which have already received model approval and model approval pertaining to those fire hoses which have received model approval based on the results of tests governed by the provisions then in force pursuant to the provision of paragraph (1) at the time of enforcement of this Ordinance shall be

Ordinance for Technical Specifications Pertaining to Power Fire Pumps (Supplementary Provisions)

- deemed to be model approval pursuant to the specifications prescribed in the Ordinance for Technical Specifications Pertaining to Fire Hoses after the revision pursuant to the provision of Article 4.
- (6) The model approval pertaining to those deluge valves which have already received model approval and model approval pertaining to those deluge valves which have received model approval based on the results of tests governed by the provisions then in force pursuant to the provision of paragraph (1) at the time of enforcement of this Ordinance shall be deemed to be model approval pursuant to the specifications prescribed in the Ordinance for Technical Specifications Pertaining to Deluge Valves after the revision pursuant to the provision of Article 5.
 - (7) The model approval pertaining to those foam concentrates which have already received model approval and model approval pertaining to those foam concentrates which have received model approval based on the results of tests governed by the provisions then in force pursuant to the provision of paragraph (1) at the time of enforcement of this Ordinance shall be deemed to be model approval pursuant to the specifications prescribed in the Ordinance for Technical Specifications Pertaining to Foam Concentrates after the revision pursuant to the provision of Article 6.
 - (8) The model approval pertaining to those detectors and transmitters which have already received model approval and model approval pertaining to those detectors and transmitters which have received model approval based on the results of tests governed by the provisions then in force pursuant to the provision of paragraph (1) at the time of enforcement of this Ordinance shall be deemed to be model approval pursuant to the specifications prescribed in the Ordinance for Technical Specifications Pertaining to Detectors and Transmitters after the revision pursuant to the provision of Article 7.
 - (9) The model approval pertaining to those water flow detection devices which have already received model approval and model approval pertaining to those water flow detection devices which have received model approval based on the results of tests governed by the provisions then in force pursuant to the provision of paragraph (1) at the time of enforcement of this Ordinance shall be deemed to be model approval pursuant to the specifications prescribed in the Ordinance for Technical Specifications Pertaining to Water Flow Detection Devices after the revision pursuant to the provision of Article 8.
 - (10) The model approval pertaining to those snap type metal couplings which have already received model approval and model approval pertaining to those snap type metal couplings which have received model approval based on the results of tests governed by the provisions then in force pursuant to the provision of paragraph (1) at the time of enforcement of this Ordinance shall be deemed to be model approval pursuant to the specifications prescribed in the Ordinance for Technical Specifications Pertaining to Snap Type Metal Couplings Used for Fire Hoses after the revision pursuant to the provision of Article 11.
 - (11) The model approval pertaining to those screw type metal couplings which have already received model approval and model approval pertaining to those screw type metal couplings which have received model approval based on the results of tests governed by the provisions then in force pursuant to the provision of paragraph (1) at the time of enforcement of this Ordinance shall be deemed to be model approval pursuant to the specifications prescribed in the Ordinance for Technical Specifications Pertaining to Screw Type Metal Couplings Used for Fire Hoses or Fire Suction Hoses after the revision pursuant to the provision of Article 12.
 - (12) Power fire pumps which were notified to the Minister of Home Affairs pursuant to the provision of Article 21-16-4 paragraph (1) of the Fire Service Act (Act No. 186 of 1948) prior to the date of enforcement of this Ordinance shall be deemed to be power fire pumps conforming to the specifications prescribed in the Ordinance for Technical Specifications

Ordinance for Technical Specifications Pertaining to Power Fire Pumps (Supplementary Provisions)

Pertaining to Power Fire Pumps after the revision pursuant to the provision of Article 9.

- (13) Fire suction hoses which were notified to the Minister of Home Affairs pursuant to the provision of Article 21-16-4 paragraph (1) of the Fire Service Act prior to the date of enforcement of this Ordinance shall be deemed to be fire suction hoses conforming to the specifications prescribed in the Ordinance for Technical Specifications Pertaining to Fire Suction Hoses after the revision pursuant to the provision of Article 10.

Supplementary Provisions (Ordinance of the Ministry of Home Affairs No. 44 of September 14, 2000)

This Ordinance shall come into force as from the date of enforcement (January 6, 2001) of the Act to Revise Parts of the Cabinet Act (Act No. 88 of 1999).

Supplementary Provisions (Ordinance of the Ministry of Home Affairs No. 47 of March 31, 2008)

- (1) This Ordinance shall come into force as from the date of promulgation.
- (2) Power fire pumps which were notified to the Minister of Internal Affairs and Communications pursuant to the provision of Article 21-16-4 paragraph (1) of the Fire Service Act prior to the date of enforcement of this Ordinance shall be deemed to be power fire pumps conforming to the specifications prescribed in the Ordinance for Technical Specifications Pertaining to Power Fire Pumps after the revision.

Supplementary Provisions (Ordinance of the Ministry of Internal Affairs and Communications No. 23 of March 27, 2013)

Excerpt

(Effective Date)

Article 1 This Ordinance shall come into force as from April 1, 2014.

Appended Table (Re: Article 16)

Pump Class	Water Discharge Performance			
	Specified Water Discharge Performance		High Pressure Water Discharge Performance	
	Specified Water Discharge Pressure (MPa)	Specified Water Discharge Rate (m ³ /min)	High Pressure Water Discharge Pressure (MPa)	High Pressure Water Discharge Rate (m ³ /min)
A-1	0.85	≥ 2.8	1.4 (1.7 for parallel series switch type pumps)	≥ 2.0 (1.4 for parallel series switch type pumps)
A-2	0.85	≥ 2.0	1.4 (1.7 for parallel series switch type pumps)	≥ 1.4 (1.0 for parallel series switch type pumps)
B-1	0.85	≥ 1.5	1.4	≥ 0.9
B-2	0.7	≥ 1.0	1.0	≥ 0.6
B-3	0.55	≥ 0.5	0.8	≥ 0.25
C-1	0.5	≥ 0.35	0.7	≥ 0.18
C-2	0.4	≥ 0.2	0.55	≥ 0.1
D-1	0.3	≥ 0.13		
D-2	0.25	≥ 0.05		

Appended Figure (Re: Article 20 and Article 30)

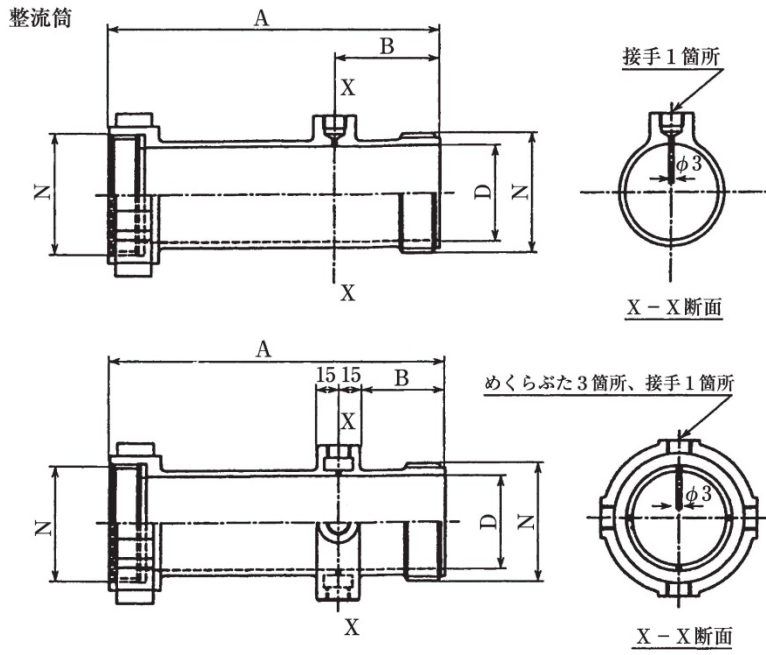

(Table)

